

**785**

SYNEL AMERICAS  
Product Manual & Guide

Synel Americas  
8665 E Hartford Dr Suite 100  
Scottsdale, AZ. 85255

480-374-7700  
[www.synel-americas.com](http://www.synel-americas.com)  
[sales@synel-americas.com](mailto:sales@synel-americas.com)

V Feb 2020

# 1.0 Technical Specifications

## 1.1 Specifications

<b>Dimensions</b>	9.8" x 6.7" x 3.7"
<b>Weight</b>	2.5 lbs.
<b>Memory</b>	512K RAM, Battery backed.
<b>Reader</b>	Magnetic Stripe (track 1, 2, or 3) – Optional Bar Code (0-of-9, 2-of-5, 128) Proximity Reader (HID 26 Bit) – Optional Fingerprint (1:1 validation 1:N identification) – Optional
<b>Display</b>	2x16 LCD backlit Alphanumeric with Decimal point
<b>Programming</b>	ASCII-based, Over Communication Port
<b>Communications</b>	Standard: RS-232 Port - Bi-directional Local Communications Standard: RS-485 Port Optional: 14.4 Baud Modem Optional: 10/100 Ethernet
<b>Power</b>	Voltage: 110/230 Vac + 10%, 100mA
<b>Environment</b>	Operating Temperature -20° -60° C Humidity: up to 95% RH

## 1.2 Available Options

**Ethernet Communications:** With the optional internal Ethernet card, the terminal can be connected to any 10/100 Ethernet network.

**Wi-Fi (Wireless) Communications:** The TA-785's wireless card allows the 745 to communicate over a standard 802.11b network. The wireless network must be configured with an IP address, gateway, subnet, and WEP key (if available).

**P.O.E. (Power over Ethernet):** The TA-785's has the optional capability of drawing its power from the Ethernet communications line. This eliminates the need for high voltage power at the terminal locations. Note: The Ethernet Network must support POE communications.

**Biometric Fingerprint Reader:** The TA-785 can store up to 9,090 fingerprint templates for biometric verification (1 to 1) or identification (1 too many). The terminal utilizes a high resolution 500 dpi finger template.



**External Readers:** The TA-785 has two reader ports to connect external devices such as a Bar code Gun or an Access Control Swipe Reader that could be mounted outside a door.

## 1.3 Features

The TA-785 is constructed of injection molded plastic, which, pound for pound is stronger than steel, yet lightweight and attractive. The terminals have recessed membrane keypads, which create a watertight seal against external elements.

### 1.3.1 Front Panel

The TA-785 Terminal has the following front panel features:

1. 2x16 Character LCD backlit display.
  - a. The terminal comes with a highly advanced filtered LCD display. This means that under almost any lighting condition, the terminal will give you a clear picture to read the screen.
2. Two arrow keys are located to the right of the display panel for line up  and line down  maneuvering.
  - a. The arrow keys are also used for getting into Technician mode.
3. Eight Function keys located on the left, below the display.
  - a. **[IN]**, **[OUT]**, **[F1]**, **[F2]**, **[F3]**, **[F4]**, **[F5]** and **[F6]**.
4. A numerical keyboard of fourteen keys, including **[Enter]**, **[Back Space]**, **[Dot]** and **[Clear]**.
5. The **Alarm** light "I", is located to the left of the display.
  - a. *The alarm light is an LED that lights when at least half of the memory is used; its blinks when the memory is almost full.*
6. The **ON** button enables a 15 second manual operation window if the terminal is on battery back-up power.

### 1.3.2 Bottom Connector Panel

The connector panel is located at the lower part of the casing, withholding the socket openings for all external connections as follows (from left to right):

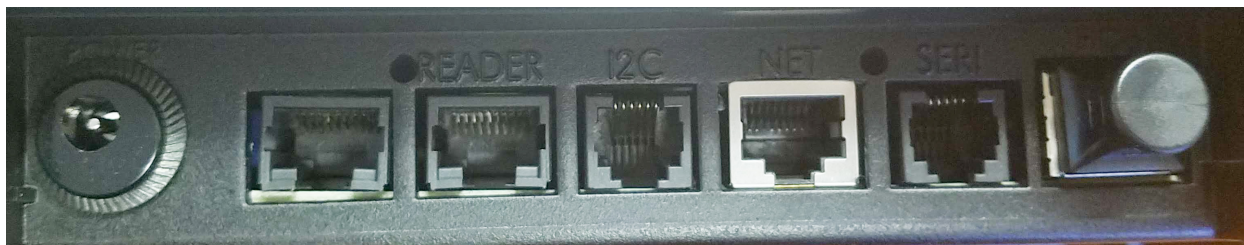

1. External secondary Reader 2 – for optional external readers
2. External secondary Reader 1 – for optional external readers
3. I<sup>2</sup>C – I/O Extension (N/A) – not used
4. Network
5. Serial I – Serial port connection for printer (N/A) – not used
6. Host – RS-232 / RS-485 Communications

### 1.4 Internal Components

The TA-785 has two back-up battery modules, one for the real time clock memory and the other for operation during a power failure.

The standard memory back-up module is a lithium battery, which will keep the internal clock running and the memory intact, for 30 days during a power failure.

The back-up battery provided (in addition to the standard memory back-up) is a self-recharging system which allows the terminal to operate during a power failure. The battery provides power for one and a half net hours of use. A shut down timeout feature enables the terminal to operate for more extended periods of time.

During a power failure, the user presses the battery key to activate the terminal. Data can then be entered and stored in the TA-785 memory. The time-out will cause the terminal to shut down automatically after the last use of the terminal, until the battery key is pressed again.

### 1.4.1 Memory

As a standard feature, the TA-785 Terminal contains a 256 Kbyte user memory, providing storage for data from more than 10,000 simple operations. This number depends on the length of the programming tables contained in the memory, and the complexity of the collected data.

*The Alarm light "!", is located to the left of the display. The alarm light is an LED that lights when at least half of the memory is used; its blinks when the memory is almost full.*

---

## 1.2 Internal Components

The TA-785 has two back-up battery modules, one for the real time clock memory and the other for operation during a power failure.

The standard memory back-up module is a lithium battery, which will keep the internal clock running and the memory intact, for 30 days during a power failure.

The back-up battery provided (in addition to the standard memory back-up) is a self-recharging system which allows the terminal to operate during a power failure. The battery provides power for one and a half net hours of use. A shut down timeout feature enables the terminal to operate for more extended periods of time.

During a power failure, the user presses the battery key to activate the terminal. Data can then be entered and stored in the TA-785 memory. The time-out will cause the terminal to shut down automatically after the last use of the terminal, until the battery key is pressed again.

### 1.2.1 Memory

As a standard feature, the TA-785 Terminal contains a 512 Kbyte user memory, providing storage for data from more than 10,000 simple operations. This number depends on the length of the programming tables contained in the memory, and the complexity of the collected data.

*The Alarm light "!", is located to the left of the display. The alarm light is an LED that lights when at least half of the memory is used; its blinks when the memory is almost full.*

---

## 2.0 Unpacking and Installation

**Note: Do not throw away the box or packing materials.**

Check the box and the contents for any signs of damage that may have happened during shipment. Carefully unpack and check the contents.

The TA-785 package contains:

<b>1 TA-785 terminal</b>
<b>Mounting panel/back plate</b>
<b>10 meter serial cable.</b>
<b>1 RJ-45 -&gt; DB9F connector.</b>
<b>Optional w/Modem: LAN Distribution Box w/6" white cable (Part#620178)</b>
<b>Four Phillips flat head 3.5x30mm and anchors, for terminal mounting purpose.</b>
<b>1 Product CD with the manuals and other tools.</b>

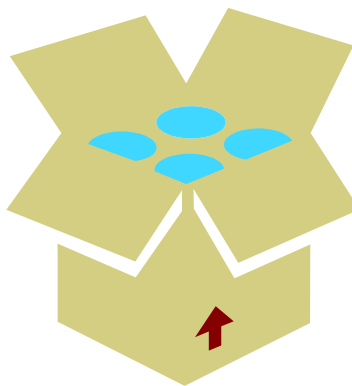

### 2.1 Location/Site Requirements

The terminal can be installed in any normal office or factory environment. Controlled environments are not required for proper operation of the terminal. However, installing and operating the terminal under adverse conditions may affect the functionality of the unit.

#### 2.1.1 Selecting a Location

Consider the following environmental factors that may affect the operation of the terminal, when considering a location:

- The cable should not be installed near EMI (Electromagnetic Interference) sources, such as:
  - Motors, generators, alternators and transformers.
  - Air conditioners, elevators, etc.
  - Radio/Television transmitters, signal generators and internal communication networks.
- Cables should not be within:
  - 30 cm. (1 ft.) from 5 KVA power lines or less.
  - 60 cm. (2 ft.) from 5-10 KVA power lines.
  - 1.5 meters (5 ft.) of power lines exceeding 10 KVA.
- Cables should not run parallel to power lines for more than 15 m. (49 ft.)

## 2.2 Mounting the Terminal

Make sure the unit is unplugged and that it is not connected to the network/PC.

***Caution: The terminal should not be mounted where it will be exposed to extreme heat or cold, water, steam, violent vibrations, high electromagnetic radiation including high voltage power lines and electrical equipment.***

---

Place the terminal near an easily accessible power source. Select an appropriate location for the terminal. The recommended height from the floor is 140 cm (4' 7").

1. Remove the back/mounting panel.
2. Using the Mounting Panel place the panel onto the wall at the correct height, making sure that the panel is level.
  - a. Mark the three holes for the screws for your drilling locations.
    - i. Drill holes using drill bit size: 0.23" (6 mm) and insert the plastic screw anchors.
  - b. Options for power cable and communication wiring.
    - i. If you are running the wiring within the wall that the clock is mounted to, you have the option of running the cabling through the center hole of the mounting plate.

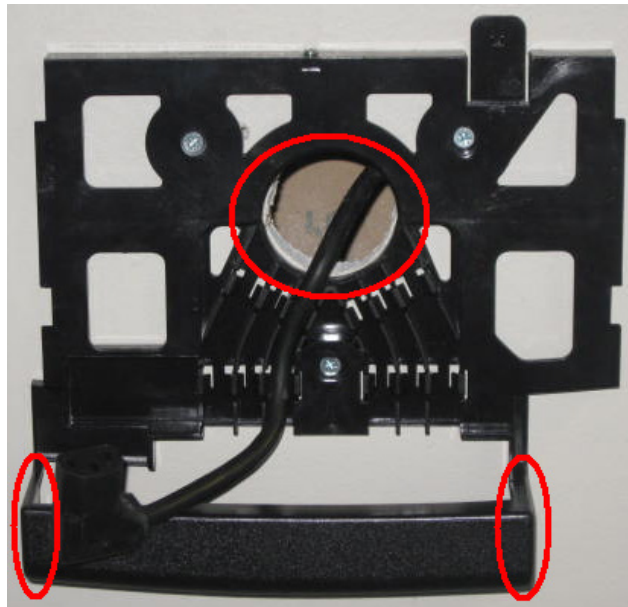

- ii. If you are bringing the cable from outside the wall, there are knockouts located on both sides of the cable shield of the mounting plate.

***Warning: Live wires in the vicinity may contain 115v or 230v. Make sure not to drill into any electric wires. Failure to heed this warning may result in serious injury or death.***

---

3. Mount the back plate making sure that the plate is level.
  - a. Use the screws that came in the kit to complete the mounting of the back plate.
4. Mount terminal by sliding the unit unto the tabs on the back of the terminal.

- a. Note: Before mounting the terminal to the back plate, you will need to plug in the electrical connection and the communications wires to the bottom of the terminal before sliding the terminal into place.

### 3.0 Terminal Configuration



The TA-785 Terminal can be connected to the host computer using either RS-232(Direct), RS-485(LAN), Ethernet including Wi-Fi or Modem connections.

#### 3.1 Entering Technician Mode

The TA-785 Terminal contains a built in configuration program called Technician mode. Technician mode enables the set-up of the following options:

Real Time clock I (RTC) calibration
Baud Rate
Fingerprint unit Baud rate
Printer Baud rate
Station ID settings
Modem Rings
Network connection settings
User Field – A field in which the user can fill-in 4 digits that will characterize that terminal

To enter technician mode:

- If the Terminal screen is displaying “NO PROG”.
  - Press the [0] key 6 times, then press [Enter].
    - *If the clock has a Barcode reader or a Magnetic reader, using a badge with six zeros (000000) will work as well.*
  - Use the [ENTER] key to move from one screen to the next. To return to the previous screen, use the [Back Space] key.
- If the Terminal screen is displaying the date and time.
  - Simultaneously press the  and  keys 6 times.
    - *If the clock has a Barcode reader or a Magnetic reader, using a badge with six zeros (000000) will work as well.*
  - Use the [ENTER] key to move from one screen to the next. To return to the previous screen, use the [Back Space] key.



## 3.2 Communication and Configuration

### 3.2.1 Communication parameters

Communication between the host and terminals is performed under an asynchronous mode. The baud rate is programmable, enabling rates from 1200 to 19200 bps.

### 3.2.2 Multiple terminal configurations

RS-485 communication enables you to connect up to 32 terminals to a single COM port and/or to extend the cabling distance to up to 1,000 meters (3,280 feet) using 9600 baud via an RS-485 multi-drop line. RS-485 communication uses three wires as opposed to RS-422 communication, which uses four wires.

### 3.2.3 Point to point configuration

A single TA-785 terminal, equipped with RS-232 communications, can be connected directly to an asynchronous RS-232 port. If RS-232 communication is used, only one terminal may be connected to each COM port and cabling distances should not exceed 50 ft.

### 3.2.5 Network connections

The terminal can be connected to one of the following communication networks:

**Ethernet (optional card)** - For this type of communication, an IP address is defined for every TA-785 terminal, enabling communication with each terminal in any 10/100 Ethernet network.

**Wi-Fi (optional card)** - For this type of communication an SSID is specified to authorize the connection and an IP address is defined for every TA-785 terminal, enabling communication with each terminal in TCP/IP protocol.

**WI-FI Technical Specification Table**

Card access current	~5V
Module current	~3.3V
Idle power consumption	200mA
Working power consumption	390~420mA
Ripple on card	6m V P-P
Ripple on module	5m V P-P
Pressure on power source at complete terminal capacity when using WI-FI/ internal magnetic reader/ external CCD reader and FPU.	~7.04V
Complete power consumption at complete terminal capacity when using WI-FI/ internal magnetic reader/ external CCD reader and FPU.	~350mA I(JP11)<1A(~250mA) I(V1)<<1A(small) I(BAT)~100mA

## 3.3 Terminal Setup

The following describes the different selections within Technician mode in the TA-785 for RS-232 communications. In bold on the left is the setting on the clock screen, and in bold on the right is the default setting. Unless otherwise specified, the settings should always be left at the default values.

### 3.3.1 RS-232

- **Adjust the RTC (N/Y):** N
  - Option is for internal clock calibration purposes.
- **Adjust host baud rate:** 19200
  - **Note:** If using XactTime, the default baud rate should be 9600.
- **Adjust fingerprint unit baud rate:** 57600
- **Adjust printer baud rate:** 19200
- **Adjust station ID:** 0
  - The Station ID is the TA-785's unique identifier for multi-terminal communication. Any number from 0 to 31 may be used as the ID, but it must match the ID in the software.
- **Adjust the amount of modem rings:** N
  - Choose **N** for no rings.
- **Network connection:** N
  - The main screen enables three modes: **N** for Serial connection, **A** (not used) **B** (10/100Base) Ethernet, or **E** for using WI-FI.
    - RS-232 uses the default **N** setting.
- **User Field:** ####
  - Specify 4 digits which characterize the terminal.
- **FPU - Setting the fingerprint unit mode** N

#### 3.3.1.1 RS-232 Connection

The TA-785 terminal can be connected to the host computer via RS-232 with the DB9 Serial Adapter and a serial cable. The maximum supported cable length for the serial cable is currently 50'.

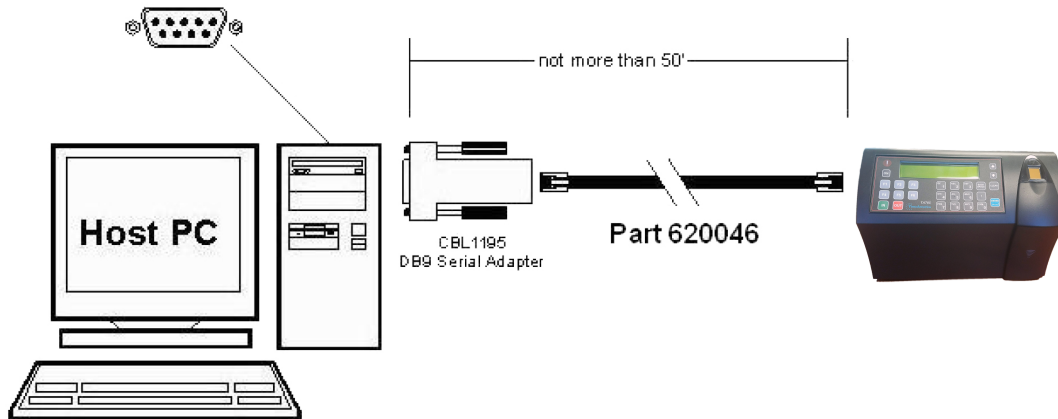

When plugging the serial cable into the clock, make sure that it is plugged into the HOST port.

### 3.3.3 Ethernet Settings

For this type of communication an IP address is defined for every TA-785 terminal enabling communication with each terminal in any 10/100 Ethernet network. Unless otherwise noted, the default settings in bold on the right should always be used.

- **Adjust the RTC (N/Y):** **N**
- **Adjust host baud rate:** **19200**
- **Adjust fingerprint unit baud rate:** **57600**
- **Adjust printer baud rate:** **19200**
- **Adjust station ID:** **0**
- **Adjust the amount of modem rings:** **N**
- **Network connection:** **B**
  - The main screen enables three modes: *N* for serial connection, *A* (not used) *B* (10/100Base) Ethernet, or *E* for using WI-FI.
- **Polling (Y/N):** **N**
- **MAC Send (Y/N):** **N**
- **My MAC Address(If Y selected above):** **#####**
- **My IP Address:** **###.###.###.###**
  - Use the numeric keys to enter the IP Address.
- **Gateway Address:** **###.###.###.###**
  - Use the numeric keys to enter the Gateway Address.
- **Remote Address:** **000.000.000.000**
  - Option not used, always left at all zeros.
- **Subnet Mask:** **###.###.###.###**
  - Use the numeric keys to enter the terminal's subnet mask.
- **My Port:** **03734**
- **Host Port:** **03734**
- **Disconct Sec:** **30**
  - Disconnect seconds defines the number of waiting seconds before reverting to offline mode, can be set up to a maximum value of 99.
- **DHCP (Y/N):** **N**
  - *Note:* TA applications uses static IP addresses for communication, as this feature is not supported. Should always be set to *N*.

#### 3.3.3.1 Ethernet Connection

When plugging the Ethernet cable into the terminal, use the NET port.

### 3.3.4 Wi-Fi Card Settings

Setting the Wi-Fi network connection is done by entering the parameters into the terminal via the keypad.

Some of the parameters are entered in HEX form. To enter the parameters in their HEX form, enter the corresponding HEX value into the terminal.

In the terminal, HEX alphabetic values are entered using the F-keys. Use the following table for the characters and their alphabetic values along with the corresponding F-keys.

Char	HEX	Char	HEX	Char	HEX	Char	HEX	Char	HEX	Char	HEX
		0	30	@	40	P	50	`	60	p	70
!	21	1	31	A	41	Q	51	a	61	q	71
"	22	2	32	B	42	R	52	b	62	r	72
#	23	3	33	C	43	S	53	c	63	s	73
\$	24	4	34	D	44	T	54	d	64	t	74
%	25	5	35	E	45	U	55	e	65	u	75
&	26	6	36	F	46	V	56	f	66	v	76
'	27	7	37	G	47	W	57	g	67	w	77
(	28	8	38	H	48	X	58	h	68	x	78
)	29	9	39	I	49	Y	59	i	69	y	79
*	2 F1	:	3 F1	J	4 F1	Z	5 F1	j	6 F1	z	7 F1
+	2 F2	;	3 F2	K	4 F2	[	5 F2	k	6 F2	{	7 F2
,	2 F4	<	3 F4	L	4 F4	\	5 F4	l	6 F4		7 F4
-	2 F5	=	3 F5	M	4 F5	]	5 F5	m	6 F5	}	7 F5
.	2 IN	>	3 IN	N	4 IN	^	5 IN	n	6 IN	~	7 IN
/	20UT	?	30UT	O	40UT	~	50UT	o	60UT		70UT

- **Adjust the RTC (N/Y):** **N**
  - Option is for internal clock calibration purposes.
- **Adjust host baud rate:** **19200**
  - Baud rates: 1200, 2400, 4800, 9600 and 19200.
  - **Note:** If using XactTime, the default baud rate should be 9600.
- **Adjust fingerprint unit baud rate:** **57600**
  - Baud rates: 57600, 9600, 19200 and 38400.
- **Adjust printer baud rate:** **19200**
  - Baud rates are: 1200, 2400 and 4800, 9600 and 19200
- **Adjust station ID:** **0**
  - The Station ID is the TA-780/785's unique identifier for multi-terminal communication. Any number from 0 to 31 may be used as the ID, but it must match the ID in the software.
- **Adjust the amount of modem rings:** **N**
  - Choose **N** for no rings.
- **Network connection:** **E**
  - The main screen enables three modes: **N** for no connection, **A** (not used) **B** (10/100Base) Ethernet, or **E** for using Wi-Fi.

- **Set/Reset/Exit:** **E**
    - **Set**
      - Select S to continue and setup the Wi-Fi settings.
    - **Reset**
      - Use this menu to reset the Wi-Fi card and to change the password.
    - **Exit**
      - Use this menu option to exit out of the Network Connection settings.
  - **Polling (Y/N):** **N**
    - Option not used, should always be N.
  - **MAC Send (Y/N):** **N**
    - If you want to confirm sending your terminal's network MAC address to the host. Then after exiting technician mode the terminal will send the host a "Hardware configuration network" message informing it of its MAC address, IP etc.
  - **My IP Address (If Y selected above):** **###.###.###.###**
    - Use the numeric keys to enter the IP Address.
  - **Gateway Address:** **###.###.###.###**
    - Use the numeric keys to enter the IP Address.
  - **Remote Address:** **000.000.000.000**
    - Always left at all zeros.
  - **Subnet Mask:** **###.###.###.###**
    - The subnet mask is the network address plus the bits reserved for identifying the sub-network. Use the numeric keys to determine the terminal's subnet mask affiliation within your local net.
  - **My Port:** **03734**
    - TCP/IP enables connecting multiple applications via the same address. The port number selected here is the application identification number used by the computer when communicating with the terminal. TA applications use the default port number 3734. However, you may change this according to your specific needs.
  - **Host Port:** **03734**
    - TA applications use the default port number 3734. However, you may change this according to your specific needs. Use the numeric keys to change the port number.
  - **Disconct Sec:** **30**
    - Disconnect seconds defines the number of waiting seconds before reverting to offline mode.
  - **DHCP (Y/N):** **N**
    - *Note:* TA applications uses static IP addresses for communication, as this feature is not supported.
  - **SSID (service Set Identifier):**
    - Entered in HEX form. The sequence of characters identifying the wireless local area network, allowing the stations to connect to a specific network when multiple independent networks operate in the same physical area.
  - **Authentication Method:**
    - Specifies the method of authentication. Set by drilling down and selecting the parameters:
      - Open
        - WEP – Enter 4 keys
          - WEP Key Number – Specify the number of the key in the sequence of 4 keys.
          - WEP Key – Enter the key.
          - Wi-Fi WEP – choose:
            - None
            - 64 bit
            - 128 bit
- **Shared Key:**
  - Set by drilling down and selecting the parameters.
    - Open
      - WEP Key Number – Specify the number of the key on the sequence of 4 keys.
      - WEP Key – Enter the key.
      - Wi-Fi WEP – choose:
        - None
        - 64 bit
        - 128 bit
    - WEP – Enter 4 keys.
      - WEP Key Number – Specify the number of the key on the sequence of 4 keys.
      - WEP Key – Enter the key.
      - Wi-Fi WEP – choose:
        - None
        - 64 bit
        - 128 bit
- **WEP (802.1x authorization):**
  - Set by drilling down and selecting the parameters.

- WEP
  - User Name
  - User Password
- **WPA PSK:**
  - Set by drilling down and selecting the parameters.
    - WEP
      - WEP PSK Password – enter password.
    - TKIP
      - WEP PSK Password – enter password.
    - CCMP
      - WEP PSK Password – enter password.
- **WPA (802.1x authorization):**
  - Set by dialing and selecting the parameters.
    - WEP
      - User Name
      - User password
    - TKIP
      - User Name
      - User password
    - CCMP
      - User Name
      - User password
- **LEAP (Cisco LEAP):**
  - Set by dialing and selecting the parameters.
    - WEP
      - User Name
      - User password
- **Reset:**
  - Password – Used to change the password.
    - Password – Enter the current password.
      - The default password is 0.
    - Change Password – Enter the new password.
    - Reset – Returns settings to the factory default.

N

### 3.3.4 Resetting the Wi-Fi Card



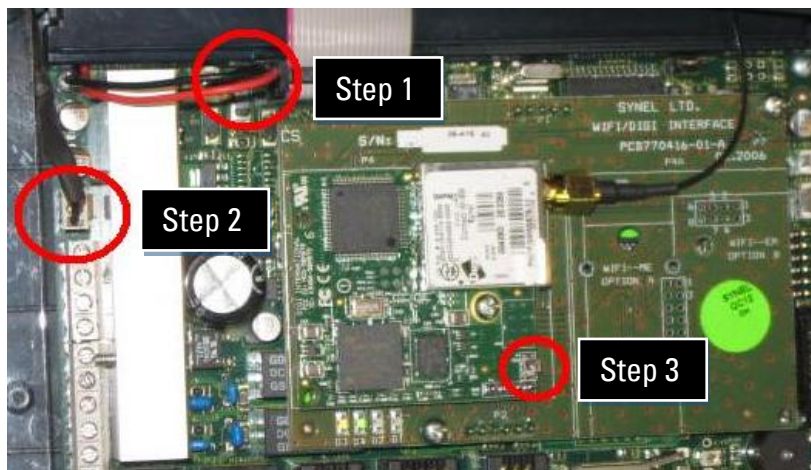

- To reset the card:
  - Step 1
    - Disconnect the battery backup cable
  - Step 2
    - Press and hold the reset button for 5 seconds
    - Disconnect the main power source, and continue to hold the reset button for an additional 30 seconds.
  - Reconnect the main power source; then reconnect the battery backup power.
- This restart process may need to be repeated more than once.



## 4.0 Terminal Maintenance

### 4.1 Recovery from Memory Error

If there is a memory error, a **MEM CRASH** message will appear on the terminal screen. You will need to clear the terminal's memory and return the terminal to the **NO PROG** (No Programming) state according to the procedure below.

1. Press the **[0]** key 6 times.
  - a. If the clock has a Barcode reader or a Magnetic reader, using a badge with six zeros (000000) will work as well.
2. Press the **[ENTER]** key 1 time.
3. Press the up arrow  3 times.
4. Press the down arrow  2 times.
5. Press the up arrow  3 times.
  - a. The message **"CLEAR MEMORY"** will appear on the display.
6. Press the down arrow  2 times.
  - a. The message **"MEMORY CLEARER"** will appear on the display.
7. Press the **[CLEAR]** button, and the message **"NO PROG"** will appear on the screen.

### 4.2 How to Reset the Memory

***Warning: This function should be performed by qualified personnel only. It requires working with an open unit. Make sure to unplug the unit wherever the instructions call for it. Failure to heed this warning may result in serious injury or death.***

---

#### 4.2.1 Location of Jumpers

Use the following steps reset the memory, causing a Memory Crash.

1. Unplug the Terminal and make sure that it is powered off.
  - a. The terminal will shut down after 15 seconds of being unplugged from the power.
2. Unscrew and remove the front panel.

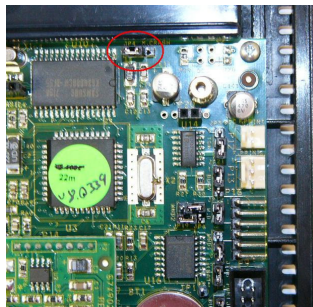

3. Remove the JP4 jumper from the 1-2 position and place it in the 2-3 position.
4. Reposition the JP4 jumper back to its original 1-2 position.
5. Replace the front panel, replacing the screws.
6. Plug the Terminal back into a power source and make sure that **"MEM CRASH"** appears in the terminal display.
7. Follow the steps from section 4.1 on recovering from the **"MEM CRASH"** state.

## 5.0 Field Upgrades and Servicing

One of the many features of the TA-785 terminal is the ability to do field upgrades and servicing. This section provides an explanation on how to perform the following upgrades:

- Internal Ethernet Card installation
- Internal Wi-Fi Card installation
- POE Card Installation
- Finger Reader Installation
- Proximity Reader Installation

***Warning: This function should only be performed by qualified/trained personnel only. It requires working with an open unit. Make sure to unplug the unit wherever the instructions call for it. Failure to heed this warning may result in serious injury or death.***

### 5.1 Procedure – Internal Ethernet Card Installation

*NOTE: Refer to the section 3.3.3 for additional information on configuration settings for this option.*

1. Unplug the power cord from the bottom of the Terminal and allow the unit to shut down after the battery backup takes over. This will last about 20 seconds.
2. Unscrew and remove the front panel; there are 5 screws on the back side of the terminal.
3. Locate the connectors that the Ethernet card will be plugging into using the follow image as a reference.

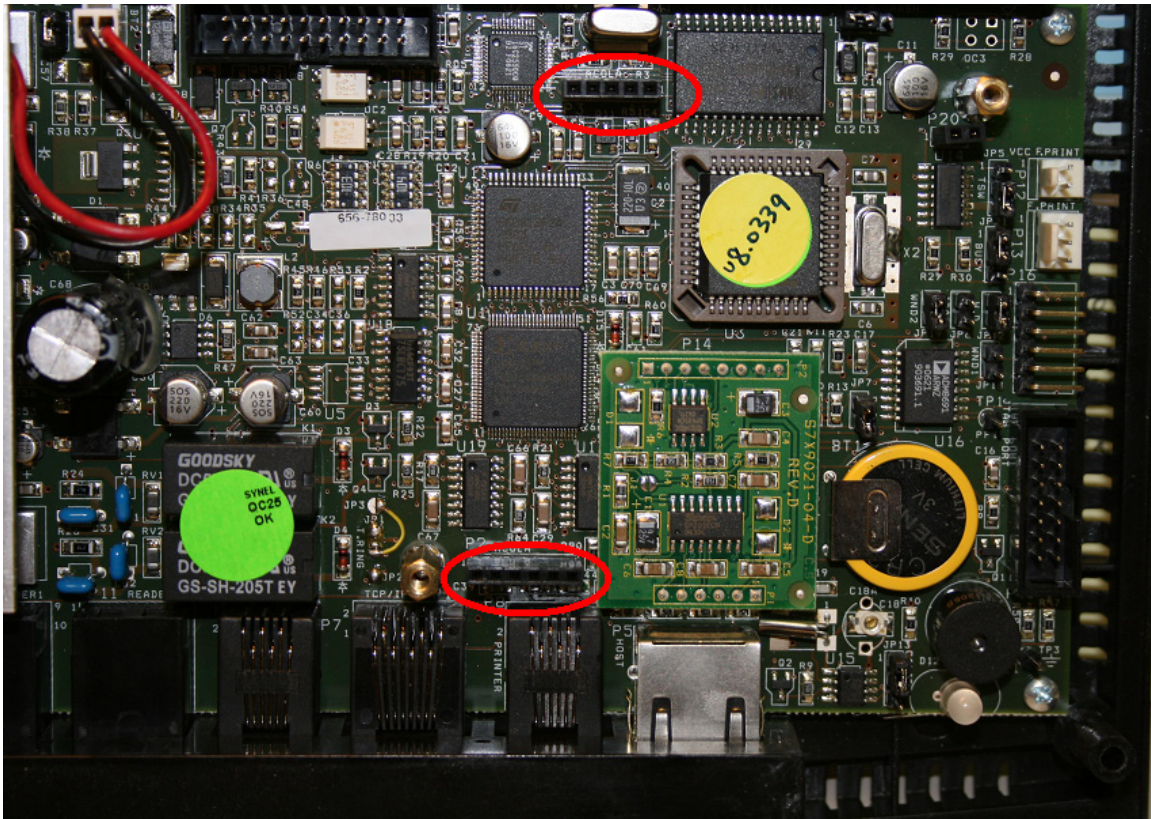

4. Line up the pins to the connectors on the board. Slide the pins into the connectors until the board rests on the two screw mounts. Use the image below as a reference for proper card placement.

### Type B

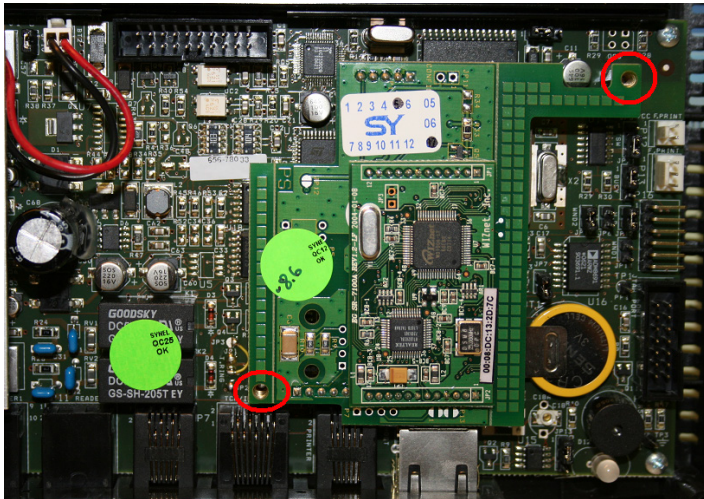

### Type F

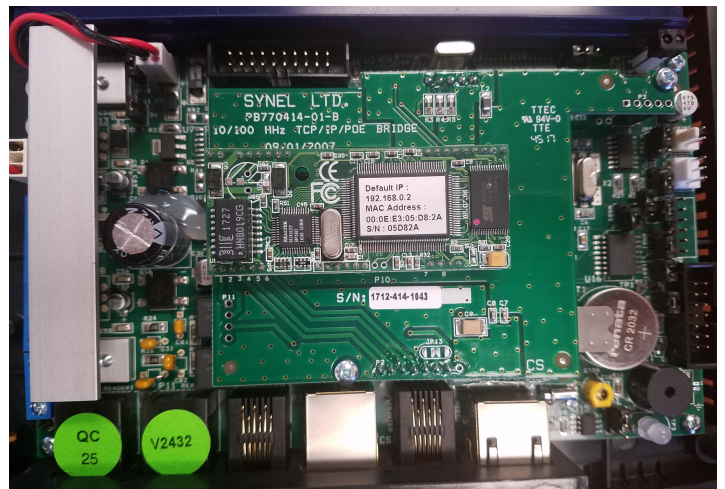

5. Insert the two screws for the Ethernet card.
6. Replace the front panel, inserting the 5 screws and being careful not to over tighten them.
7. Plug the Terminal back into a power source and make sure that the date/time appears in the terminal display.
8. Plug the Ethernet cable into the NET port at the bottom of the terminal.



## 5.3 Procedure – Internal Wi-Fi Card Installation

**NOTE:** Refer to the section 3.3.4 for additional information on configuration settings for this option.

1. Unplug the power cord from the bottom of the Terminal and allow the unit to shut down after the battery backup takes over. This will last about 20 seconds.
2. Unscrew and remove the front panel; there are 5 screws on the back side of the terminal.
3. Locate the connectors that the Wi-Fi card will be plugging into using the follow image as a reference.

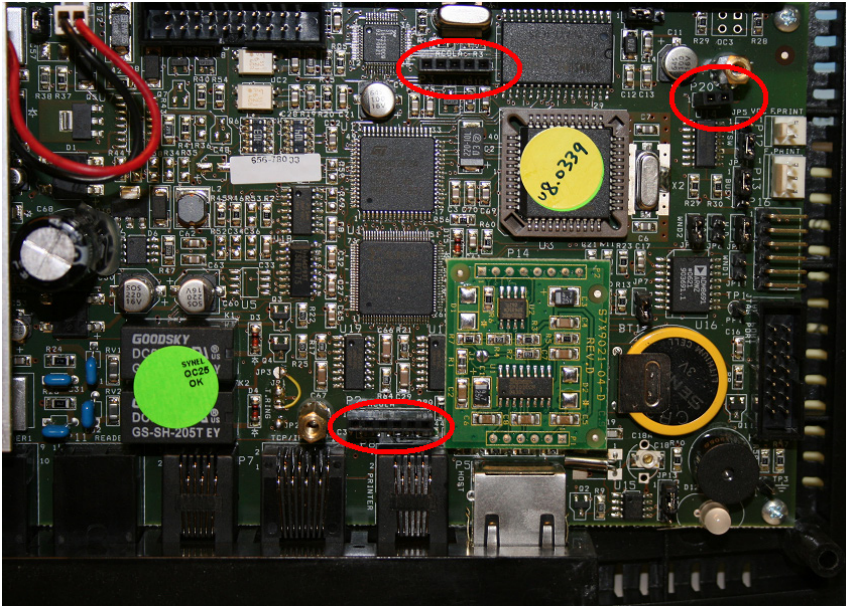

4. Line up the pins to the connectors on the board. Slide the pins into the connectors until the board rests on the two screw mounts. Insert the two screws that came with the card into the two screw mounts. Use the image below as a reference for proper card placement.

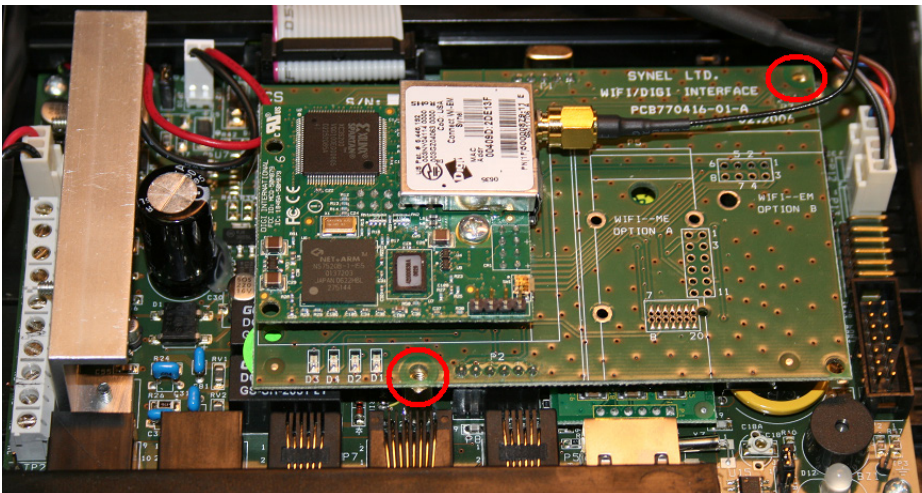

5. Using the mounting piece and the zip tie that came with the Wi-Fi card, secure the Antenna to the interior of the front panel.
6. Replace the front panel, insert the screws inserting the 5 screws and being careful not to over tighten them.
7. Plug the Terminal back into a power source and make sure that the date/time appears in the terminal display.

## 5.4 Procedure – POE Card Installation

**Warning:** These functions should only be performed by qualified personnel only. It requires working with an open unit. Make sure to unplug the unit wherever the instructions call for it. Failure to take the proper precautions may result serious injury or death.

**NOTE:** Refer to the section 3.3.3 for additional information on configuration settings for this option.

1. Unplug the power cord from the bottom of the Terminal and allow the unit to shut down after the battery backup takes over. This will last about 20 seconds.
2. Unscrew and remove the front panel; there are 5 screws on the back side of the terminal.
3. Unplug the connector for the display, and if equipped, the connectors for the fingerprint. See image below for locations of connectors. You can now move the cover away from the unit.
4. Disconnect the connectors for the main power and battery backup
  - a. If necessary, remove the cover for the battery compartment if it's in the way.

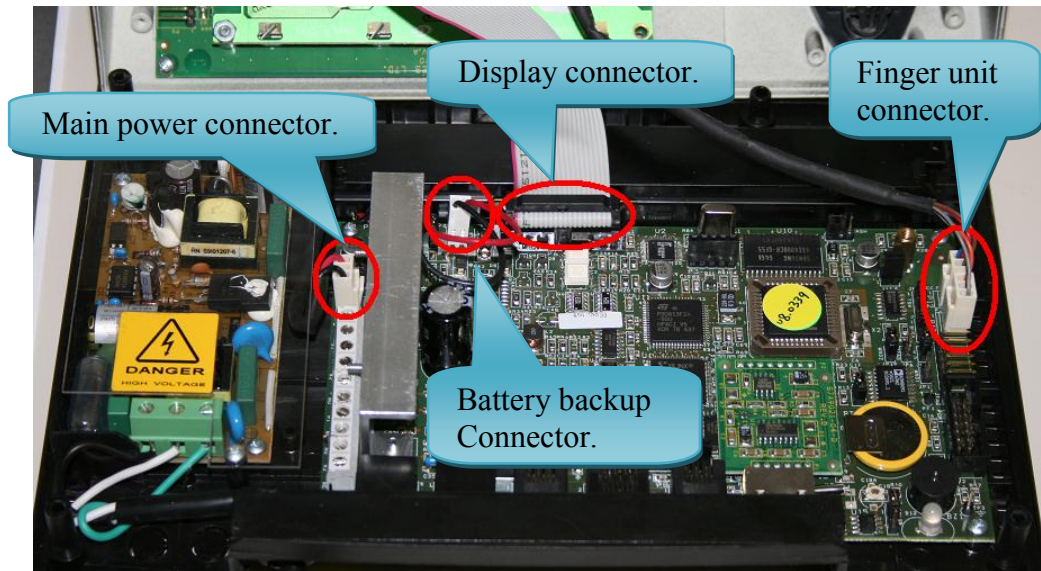

5. Remove the 4 screws that hold in the main board. See image below for locations of screws.

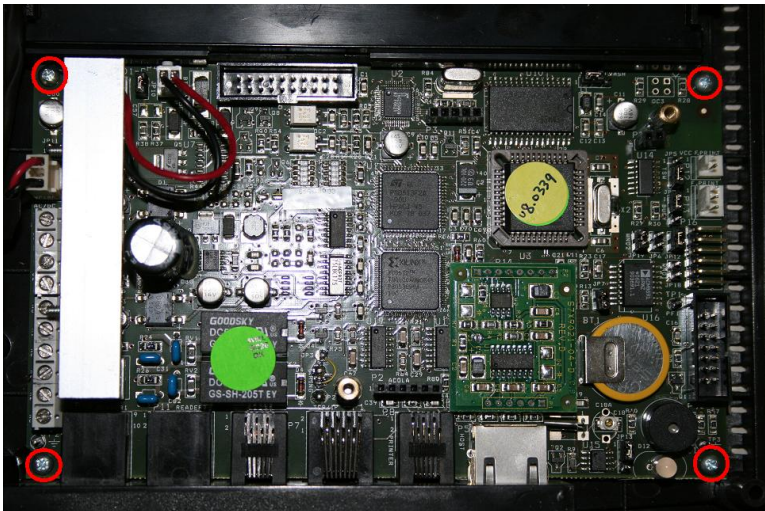

6. Remove the main board from the unit.
7. Remove the screws from the plastic protection cover on the power board.

**Warning:** *Be very careful when handling the power board, failure to take proper precautions may result in serious injury or death.*

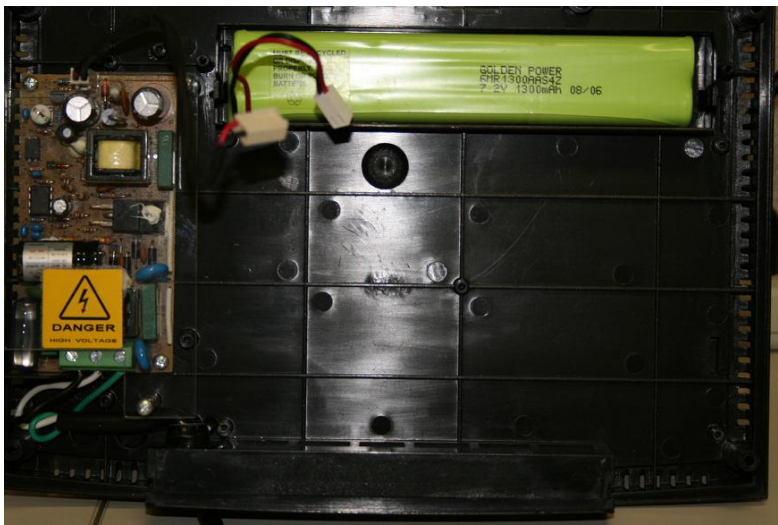

8. Remove the power cable by loosening the 3 screws for the black, white and green wires and pulling them from the connectors. Remove the power cable from the unit.
9. Remove the two screws from the power board, and then remove the board from the unit.
10. Place the power and the new main board into place, using image below as a reference. Insert the two screws for the power board and the four screws for the main board.



11. Reconnect the power wire for the backup battery.
12. Reconnect the cables for the display and if equipped the cables for the Fingerprint.
13. Replace the front panel and the four screws.

## 5.5 Procedure – Finger Reader Installation

1. Unplug the power cord from the bottom of the Terminal and allow the unit to shut down after the battery backup takes over. This will last about 20 seconds.
2. Unscrew and remove the front panel; there are 5 screws on the back side of the terminal.
3. Pop out and replace the plug with the holder for the finger reader. Place the reader into the holder as shown in the image below.

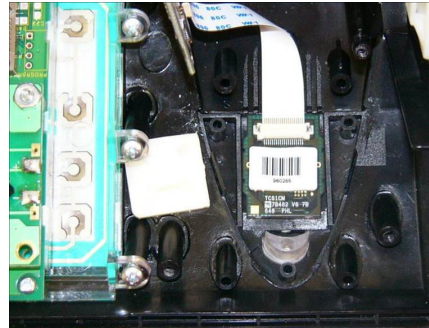

4. Place the back of the holder onto the unit, and insert the three screws to hold it place. See image below.
5. Using two screws, mount the board for the unit onto the two pegs as seen in the image below, and plug the

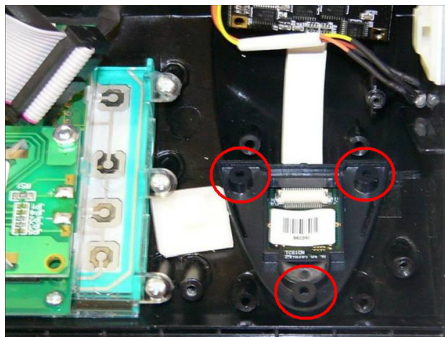

light from the reader into the clear slot on the holder.

6. Replace the front panel, insert the screws inserting the 5 screws and being careful not to over tighten them.

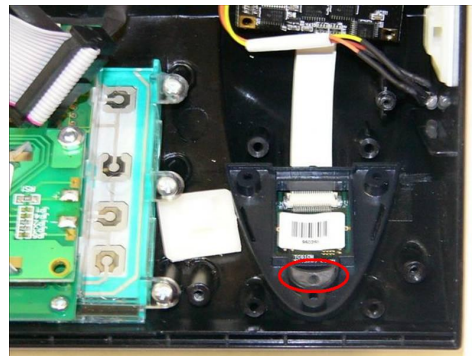
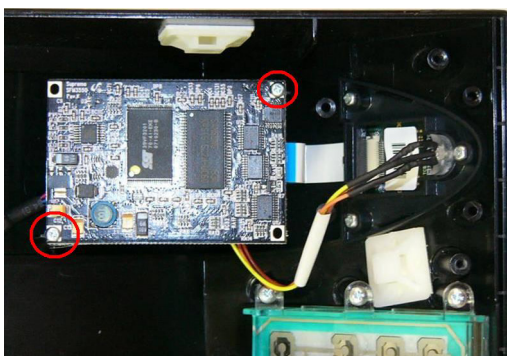

7. Plug the Terminal back into a power source and make sure that the date/time appears in the terminal display.

## 5.6 Procedure – Proximity Reader Installation

1. Unplug the power cord from the bottom of the Terminal and allow the unit to shut down after the battery backup takes over. This will last about 20 seconds.
2. Unscrew and remove the front panel; there are 5 screws on the back side of the terminal.
3. Using the image below as a guide, attach the proximity reader into the unit using the two screws that came with the kit.

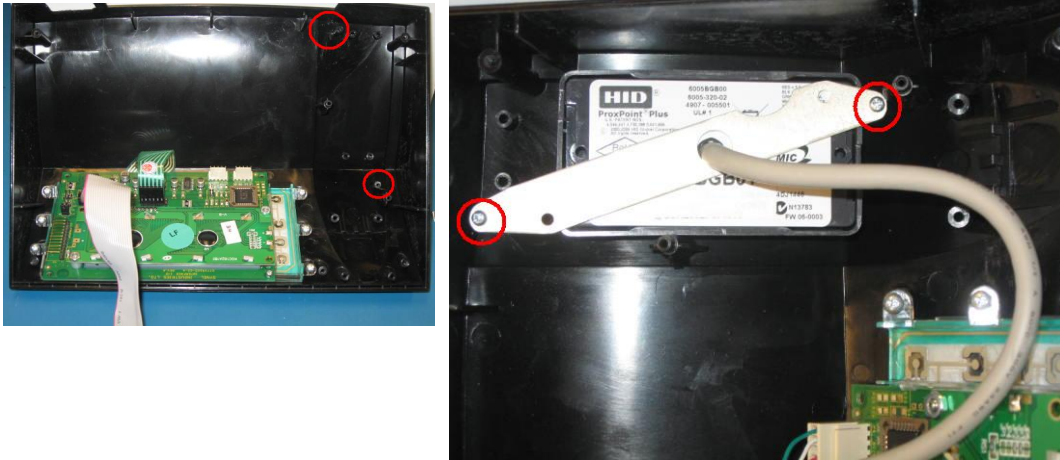

4. Plug the connector from the reader into the P4 connector using the image below as a guide. Plug the jumper that came with the kit onto the connector as shown in the image below.

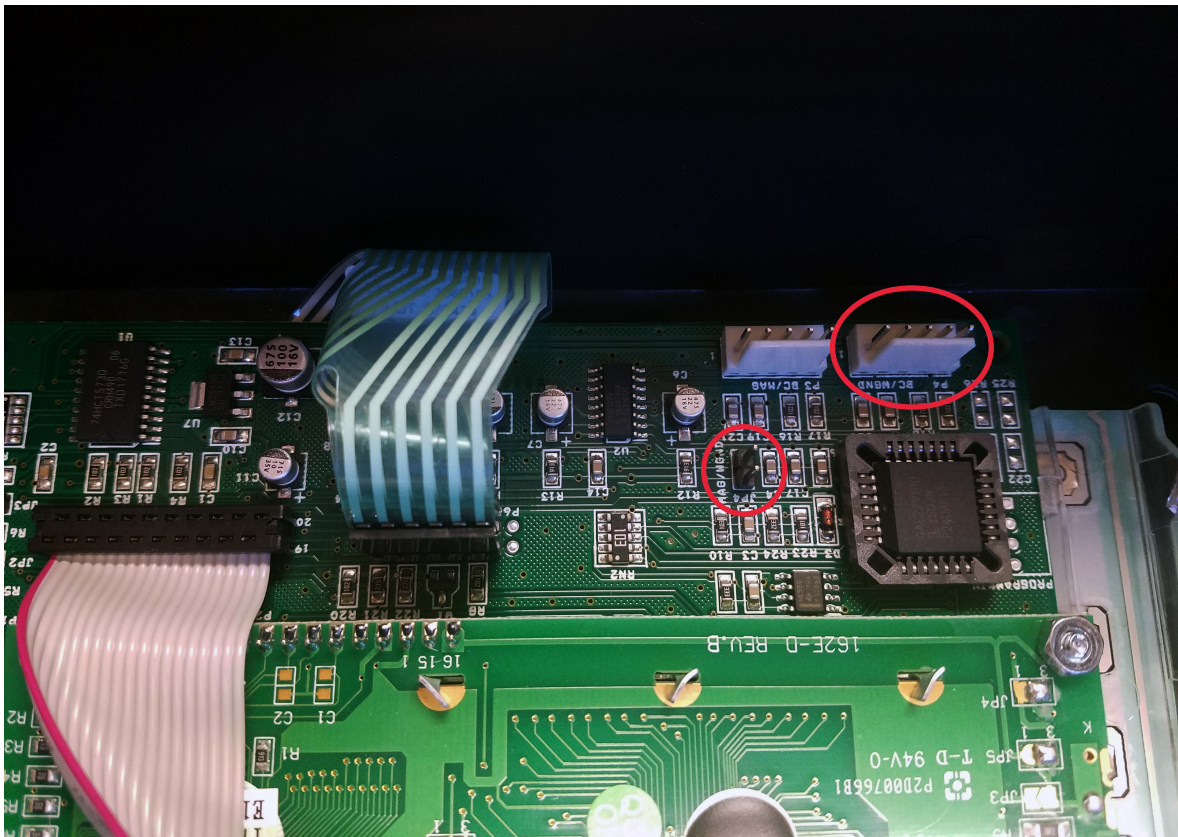

5. The Setup should now look like the image below.

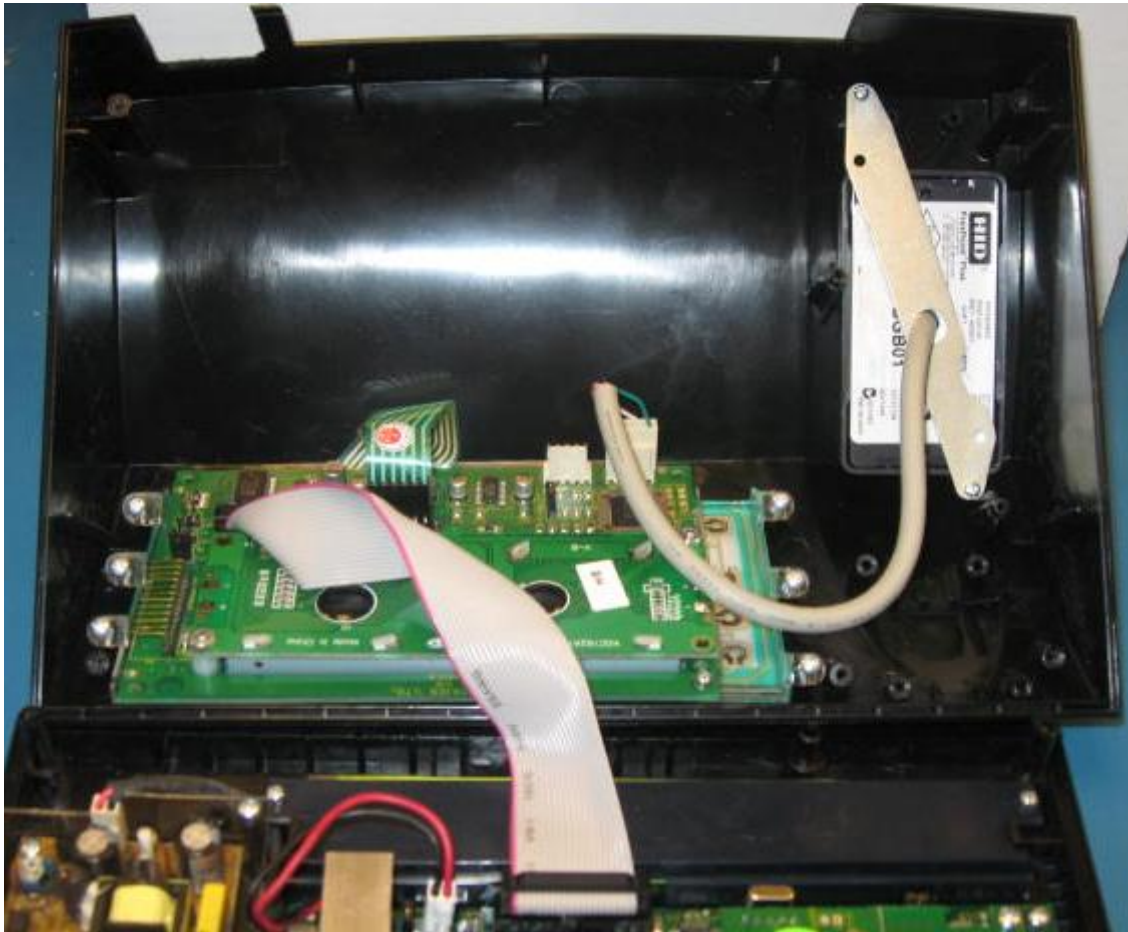

6. Replace the front panel, insert the screws inserting the 5 screws and being careful not to over tighten them.
7. Plug the Terminal back into a power source and make sure that the date/time appears in the terminal display

# Appendix – A

## Supervisor Mode

You can assign multiple badge numbers to enter into Supervisor mode, but you cannot use these numbers to clock in with.

### A.1 Enrolling Employees into the Terminal

*NOTE: The clock is programmed initially with a supervisor badge of 11111. This badge number will normally be cleared the first time you program the clock if you use different badge numbers or badge lengths for supervisors.*

---

Use the following steps to enroll users into the terminal:

- Step 1. Enter the supervisor badge number and press **[ENTER]**.
- Step 2. From the menu that appears select (3) for Finger Templates.
- Step 3. From the next menu select (1) for Enroll.
- Step 4. Enter the Badge number for the employee and press **[ENTER]**.
- Step 5. Have the employee place their finger onto the reader when it prompts you.
- Step 6. You will get a quality score, and it will take you back to the enter Badge number screen. You can then continue to enter badge numbers and enroll new employees.
  - a. For best results you will want both scores to register 80 or higher.
  - b. If you do not get scores of 80 or higher, you can try to enroll another finger.
    - i. **NOTE: Before trying to re-add your template, or to try to enroll a different finger, always delete the user first**
- Step 7. Press **[BACK SPACE]**, to get back to the previous menu.
- Step 8. If you are done enrolling, press **[BACK SPACE]** until you clear out of the menu, the clock will beep and say cancelled when exiting from the menus, this is normal.

*NOTE: Do not use [CLEAR] to go back in the menus, or to exit out of supervisor mode. This may clear out what changes or additions you made in supervisor mode.*

#### A.1.1 Re-enrolling employees

Use the following steps to re-enroll users into the terminal.

- Step 1. Enter the supervisor badge number and press **[ENTER]**.
- Step 2. From the menu that appears select (3) for Finger Templates.
- Step 3. From the next menu select (2) for Delete.
- Step 4. Enter the Badge number for the employee you want to reenroll and press **[ENTER]**.
- Step 5. Press the **[BACK SPACE]** key to go to the previous menu.
- Step 6. Then select (1) for Enroll.
- Step 7. Enter the Badge number of the employee you are re-enrolling.
- Step 8. Have the employee place their finger onto the reader when it prompts you.
- Step 9. You will get a quality score, and it will take you back to the enter Badge number screen. You can then continue to enter badge numbers and enroll new employees.
  - a. For best results you will want both scores to register 80 or higher.
  - b. If you do not get scores of 80 or higher, you can try to enroll another finger.
    - i. **NOTE: Before trying to re-add your template, or to try to enroll a different finger, always delete the user first**
- Step 10. Press **[BACK SPACE]**, to get back to the previous menu.
- Step 11. If you are done enrolling, press **[BACK SPACE]** until you clear out of the menu, the clock will beep and say cancelled when exiting from the menus, this is normal.

**NOTE: Do not use [CLEAR] to go back in the menus, or to exit out of supervisor mode. This may clear out what changes or additions you made in supervisor mode.**

### A.1.2 Deleting an Employee Template from the terminal

Use the following steps to remove a user from the terminal.

- Step 1. Enter the supervisor badge number and press **[ENTER]**.
- Step 2. From the menu that appears select (3) for Finger Templates.
- Step 3. From the next menu select (2) for Delete.
- Step 4. Enter the Badge number for the employee you want to remove and press **[ENTER]**.
  - a. If you need to delete another employee you can continue to enter numbers one at a time, pressing **[ENTER]** after each.
- Step 5. If you are done enrolling, press **[BACK SPACE]** until you clear out of the menu, the clock will beep and say cancelled when exiting from the menus, this is normal.

**NOTE: Do not use [CLEAR] to go back in the menus, or to exit out of supervisor mode. This may clear out what changes or additions you made in supervisor mode.**

### A.1.3 Proper Finger Placement

The basics for successful operation of the FPU are important. System performance improves dramatically with **consistent finger placement**. It is important to make sure that the position of the finger allows the FPU to record the unique features of the print. Follow the steps below for trouble-free fingerprint recognition.

- With the fingertip raised, position the finger so that the Ridge- Lock rests comfortably. Then, lower the finger onto the sensor and apply moderate pressure. The figure below illustrates proper finger placement and the resulting image of the scanned fingerprint.



#### A.1.3.1 Fingerprint Unit Guidelines and procedures:

- Avoid using thumb and pinky fingers since they are typically awkward to position consistently on the sensor.
- Place the higher joint of your finger on the ridge lock and lower your finger onto the sensor surface (make sure all other fingers are held straight to avoid creating an angle between the enrolled finger and the sensor surface - incorrect positioning).
- If your finger is extremely dry, touch your forehead or the side of your nose before placing it on the sensor.
- Do not use a wet/moist finger for scanning.

## A.2 Adding Transactions

Use the following steps to add transactions into the terminal:

*NOTE: The clock is programmed initially with a supervisor badge of 11111. This badge number will normally be cleared the first time you program the clock if you use different badge numbers or badge lengths for supervisors.*

---

- Step 1. Enter the supervisor badge number and press **[ENTER]**.
- Step 2. From the menu that appears select (1) Transactions.
- Step 3. From the next menu select (1) Add.
- Step 4. Enter the date of the transaction in MM/DD/YY format, then press **[ENTER]**.
- Step 5. Enter the time of the transaction in military format, then press **[ENTER]**.
- Step 6. Enter the badge number of the employee, then press **[ENTER]**.
- Step 7. Enter the function for the transaction.
- Step 8. Terminal will request finger of the employee if the unit has a finger print reader.
- Step 9. Press **[BACK SPACE]**, to get back to the previous menu.
  - a. Note: Do not use the **[CLEAR]** key to exit out of the menus as this may cancel what you have just changed or added.

## A.3 Diagnostics Mode

### A.3.1 Guidelines and procedures for Diagnostics Mode:

Use the following step to go through the options within the Diagnostics Mode of the terminal:

- Step 1. Enter the supervisor badge number and press **[ENTER]**.
- Step 2. From the menu that appears select (2) Diag (or Diagnostics if no finger reader is installed).
- Step 3. Complete the testing for each group you want to diagnose, pressing the **[ENTER]** key to go onto the next test item or using the **[BACKSPACE]** key to the previous test item:
  - a. **Mag or Prox**– stands for Magnetic or Proximity Reader
    - For Terminals that are equipped with a Magnetic or Proximity reader, if you swipe the badge or bring the badge to the terminal it will display the number of the badge on the screen.
  - b. **BC**– stand for Bar Code Reader
    - For Terminals that are equipped with a Bar Code reader. The Screen displays 4 options for the type of badge you are using, select the badge type by pressing it's corresponding number associated with your badge type.
    - If you swipe the badge it will display the number of the badge on the screen.
  - c. **Select Relay 1-2**– for testing of the terminals two relay ports.
    - For testing equipment connected to the terminals relays.
    - Press the corresponding number associated with the relay you have connected to the terminal and it will cause that relay to engage.
  - d. **Select Led#: 1-6**– this feature is not used
    - This feature is not used, you can press the **[ENTER]** key to bypass the option.
  - e. **Select Sensor 1-4**– this feature is not used.
    - This feature is not used, you can press the **[ENTER]** key to bypass this option.
  - f. **Keypad**– used for testing the keys on the keypad
    - Press the keys on the keypad and they will display to the screen.
- Step 4. Press **[ENTER]** to exit out from the last Diagnostics menu selection.

## Appendix – B

### Proximity Setup

#### B.1 Setting up the Proximity Reader

The proximity reader has the opportunity to read the badges several different ways depending on the badge type. Use the following steps to setup the clock to identify the badge.

- Step 1. Press the <F2> key and the <F5> keys simultaneously 6 times.
  - You will see on the screen “Wiegand Setup Bring Badge”
- Step 2. Place the badge next to the clock as you would to clock in.
- Step 3. The clock will beep and on the screen will display the badge number it is reading.
  - If you want to use that number, press **[ENTER]** and the clock will always read those badges with that number.
    - **NOTE:** The number showing may have a facility code (3 digit for 26-Bit badges, but may be longer depending on badge) in front of the badge number you are looking for.
  - If you don't see the number your looking for, bring the badge to the terminal again, and if possible the terminal will display an alternative badge number.
    - Repeat this process until you see the correct number.
  - If the clock can not read the badge as another number is will go back to the Time and Date on the screen.

**Appendix – C**  
**Error Messages**

<b>Code</b>	<b>Error Message</b>
000	UNKNOWN ERROR
095	NO FINGER DETECT
096	FPU IS BUSY
097	SUCCESS
098	SCAN SUCCESS
099	SCAN FAILED
105	TMPL NOT FOUND
106	TMPL NOT MATCHED
107	TRY AGAIN
108	TIME OUT
109	FPU MEMORY FULL
110	USER ID EXISTS
112	CHECK USER ID
113	ADD NEW TEMPLATE
114	OVR FINGER LIMIT
116	CONTINUE
117	CMD UNSUPPORTED
118	INVALID USER ID
119	AUTO ASSIGN ID
120	TIMEOUT MATCH

# Appendix – D

## Internal Wiring Diagrams

### D.1 Bells and Access

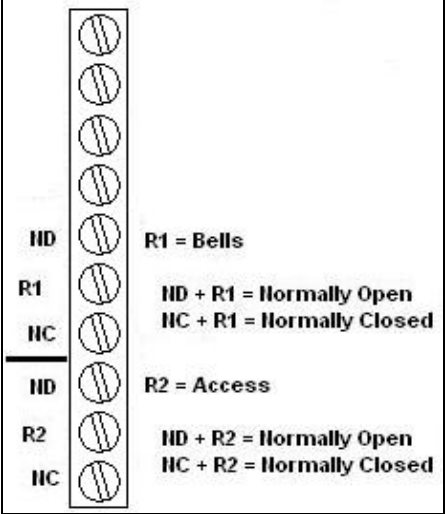

### D 1.1 Signal Control

With the TA-780's internal relay, the terminal can control a 30 VDC, 1 Amp dry-contact circuit. The signal control relay can be turned on by both a specific employee badge/number for access control or by time of day for bell ringing. The duration time is also programmable.

# Appendix – E

## External Wiring Diagrams

### E.1 RS-232

RS-232 uses the DB9 Serial Adapter and a serial cable.

*Note: Supported distances for cabling is currently 50 feet.*

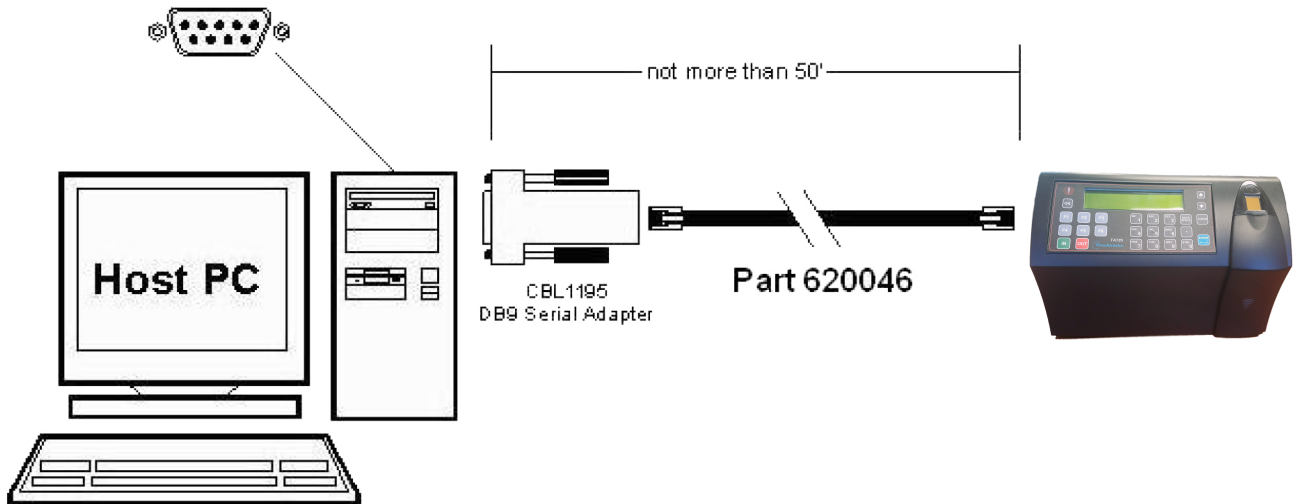

**Cable: 620046 - Serial Cable**  
RS-232 Communications

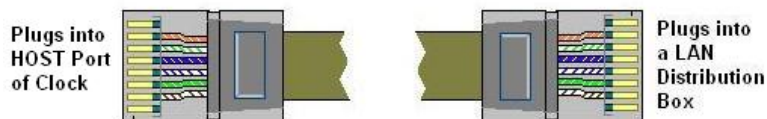

## Appendix – E

### External Connectors



#### HOST

##### RJ-45 (8-pin) RS-232

Pin	Signal	Value	Remarks
1	NC		
2	RS-485 (-TRX)	0-5 Volt	
3	RS-485 (+TRX)	0-5 Volt	
4	GND		
5	RS – 232 (TXD)	-/+15Vdc	Standard RS-232 levels
6	RS – 232 (RXD)	-/+15Vdc	Standard RS-232 levels
7/8	NC		

#### NET

##### RJ-45 (8-pin) Ethernet

Pin	Signal	Value	Remarks
1	Transmit data	TX +	
2	Transmit data	TX	
3	Receive data	RX +	
4	NC/Vin/Shield	OP	100Base-T/Modem
5	NC/Vin/Shield	OP+	Modem
6	Receive data	RX -	
7/8	NC/GND/Shield		10Base-T/Power over LAN/100Base-T

#### READER

##### RJ-45 (10-Pin) External Reader (Magnetic/Barcode)

##### Magnetic Reader

Pin	Signal	Value	Remarks
1	Data		For RS-422 signal only
2	Led 1		
3	Led 2		
4	VCC		
5	GND		
6	Led 3		
7	Clock		Clock +, For RS-422
8	DATA		Data +, For RS-422
9	VS	9v	
10	Clock		For RS-422 signal only

## Barcode Reader

Pin	Signal	Value	Remarks
1	Data(-)		For RS-422
2	Led 1		
3	Led 2		
4	VCC		
5	GND		
6	Led 3		
7			
8	DATA		Data +, For RS – 422
9	VS	9v	
10			